

## MLS50-SM

### 50mm Surface Mounted Louvre

This is a Boxed Frame Louvre design and uses 50mm louvres

To ensure long life, all parts are manufactured with high grade aluminium extrusions and a 10 year colour fastness is offered with all paint finishes

More details are given in the Technical Specification below, but if you require further information, please contact us

<b>Type</b>	<ul style="list-style-type: none"> <li>• Surface mounted Louvre System with a 50mm Blade Pitch</li> <li>• Z-Shaped Louvres</li> <li>• Frame profiles have a total height of 36 mm</li> </ul>								
<b>Material</b>	<table border="0"> <tr> <td>Aluminium</td> <td>All parts (frame profile, clips, blades etc) are manufactured from aluminium extrusions AIMg Si 0.5</td> </tr> <tr> <td>Profile Thickness</td> <td>Minimum 1.5mm</td> </tr> <tr> <td>Finish</td> <td>Natural anodising to 15-22µm with Powder Coating available in any RAL or BS colour</td> </tr> <tr> <td>Protection</td> <td>Nylon insect mesh fitted as standard with Stainless Steel or Gas meshes also available</td> </tr> </table>	Aluminium	All parts (frame profile, clips, blades etc) are manufactured from aluminium extrusions AIMg Si 0.5	Profile Thickness	Minimum 1.5mm	Finish	Natural anodising to 15-22µm with Powder Coating available in any RAL or BS colour	Protection	Nylon insect mesh fitted as standard with Stainless Steel or Gas meshes also available
Aluminium	All parts (frame profile, clips, blades etc) are manufactured from aluminium extrusions AIMg Si 0.5								
Profile Thickness	Minimum 1.5mm								
Finish	Natural anodising to 15-22µm with Powder Coating available in any RAL or BS colour								
Protection	Nylon insect mesh fitted as standard with Stainless Steel or Gas meshes also available								
<b>Design</b>	<p>The aluminium louvre clips are slid into the frame profile and the aluminium louvre blades are clipped into the louvre clips</p> <p>Blade Pitch = 50 mm</p> <p>Visual Free Area = 78%</p> <p>Reinforcement profile carrying extra blade supports are fitted when louvre widths &gt; 700mm</p>								
<b>Manufacture</b>	Custom made to measure by our skilled craftsmen to our exact requirements								
<b>Powder Coating</b>	<p>Powder Coating Thickness = 60-80 µm</p> <p>Any RAL or BS Colour available</p> <p>10 Year guarantee on colour fastness (Qualicoat)</p>								

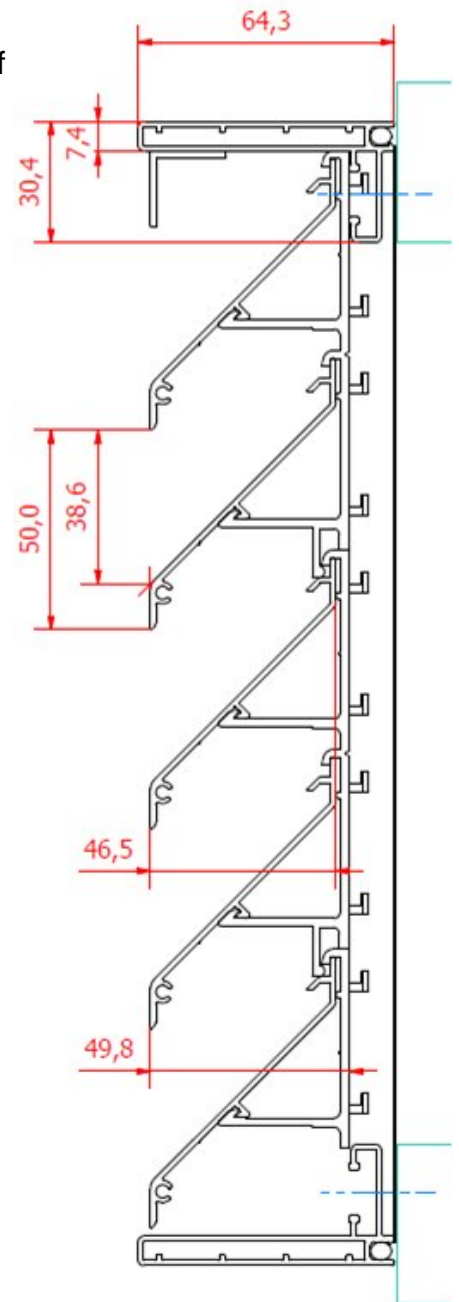

## VIVA G&S Ltd

Unit 1, 219 Torrington Avenue, Coventry CV4 9HN

Tel: 02476 694500

Website: [www.viva-group.co.uk](http://www.viva-group.co.uk)

Fax: 02476 474333

Email: [enquiries@viva-group.co.uk](mailto:enquiries@viva-group.co.uk)



ISO9001:2008  
Certificate No. FM547243